

Calculation of the container for municipal waste collection and simulation of welds using FEM

PETR Karel^{1,a}

¹Czech Technical University in Prague, Faculty of Mechanical Engineering, Department Designing and Machine Components, Technická 4, 166 07 Prague 6, Czech Republic

^akarel.petr@fs.cvut.cz

Keywords: Container, Finite Element Methods, Welds, Stress-strain Analysis, Frame

Abstract. The aim of the article is the design and stress-strain analysis of the container for municipal waste. For stress-strain analysis has been used analytical and FEM (Finite Element Methods) calculations. The container has been designed to be transported on hook-type car and ISO container chassis (the container contains ISO corner elements). For handling, the container was equipped with holes for forklift. The container can be stacked through ISO corner elements.

Introduction

Container for municipal waste designed in this work is shown in Fig. 1. For the design of container was very important implemented following parts (elements) into construction of container, because container will be transported on hook-type car and ISO container chassis.

- Hook – for transported on hook-type car.
- ISO corner elements [1] – for transported on ISO container chassis.
- Two holes for forklift – for transport by forklift.
- ISO corner elements – for stacking the container.

All parts in container were connected with beams (longitudinal, transverse and vertical) by help welds (see Fig. 1.).

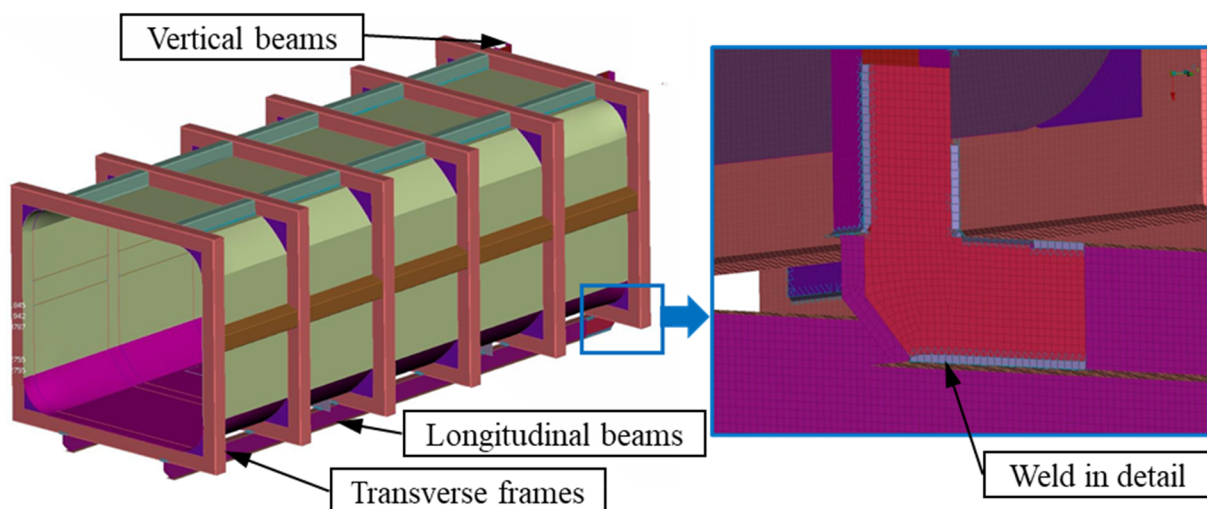

Fig. 1: Model for FEA (Finite Element Analysis) with indication of important parts (left part); Detail on simulation of welds in FEM with adhesive line and FEM mesh (right part)

For stress-strain analysis has been used analytical and FEM (Finite Element Methods) calculations.

Material and Methods

Basic parameters of the container: Outer dimensions of the container (2 438 mm – ISO width [2], 2 000 mm – height, 5 000 mm – length); Total waste weight 12 500 kg; Total container weight 2 354 kg; Volume of waste 13.5 m³; Material of container – structural steel S355J2H with yield strength $Re = 355 \text{ Nmm}^{-2}$; and $\sigma_{\text{weld}} = 100 \text{ Nmm}^{-2}$ [3]; Safety factor $k = 1.5$.

All profiles of beams used on container are calculated according analytical calculations. Specifically, using Vereščagin's rule of calculating Mohr's integral. According to these moments, profiles were proposed. The Fig. 2 (left part) shown resulting bending moment on the frame (without cylindrical reinforcement plate) – result has been obtained from analytical calculation.

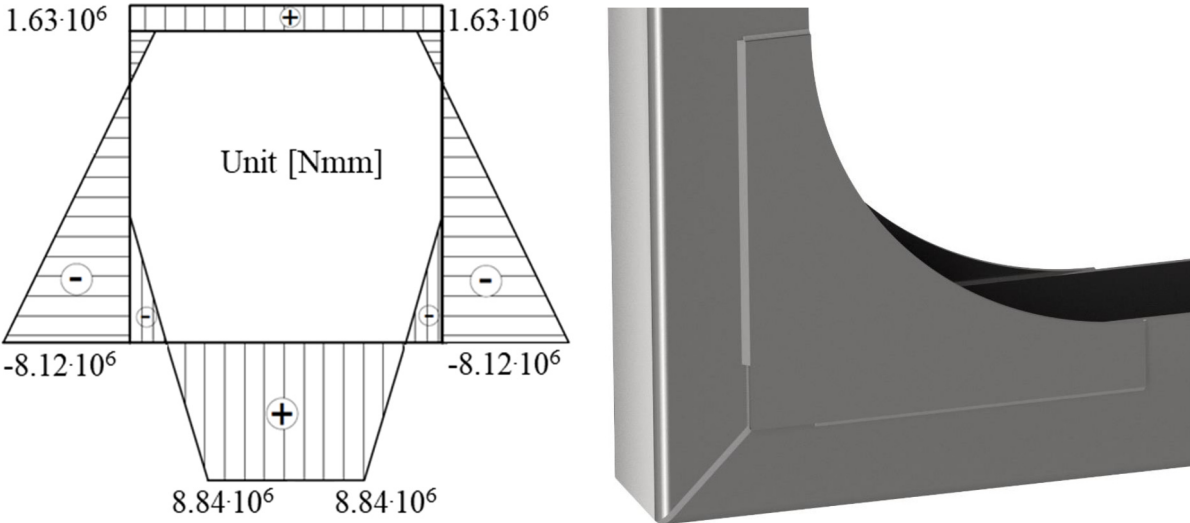

Fig. 2: The resulting bending moment on the frame (without cylindrical reinforcement plate) (left part); Detail of U-profile connection (bent sheet) of frames (right part)

Connected profiles and overall construction was realized as a weldment (see text above). The proposed construction detail (Fig. 2. right side) was made by cutting the profile ends at a 45° angle and then creating a butt weld. 5 mm thick stiffeners are used to reduce butt stress and to reinforcement the inner sheet. These reinforcements are welded with corner welds with sufficient offset from the butt weld to avoid stress concentration.

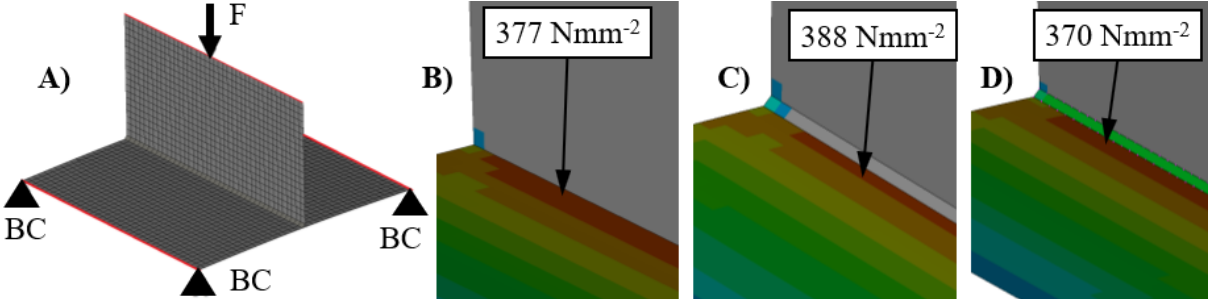

Fig. 3: A) Bearing and load designation; B) Mises stress distribution without weld joint modeling; C) Mises stress distribution for modeling of welds with shell elements; D) Mises stress distribution for modeling of welds with "adhesive line"

Before creating of final calculation FEM model, was tested different types of creation (application) of welds in FEM (see Fig. 3). Sheets of container was realized as shell. Welding modeling was realized in three ways. The first option was without welds - only sheets (Fig. 3 - B). The edge of one sheet had common nodes with the mesh of the other sheet. The second option was to define the weld using a shell layer (Fig. 3 - C). This method was very difficult, because was needed mesh quality. Many elements had to have a given height and angle of 45° . The third option was defined by "adhesive line" (Fig. 3 - C). The weld was created by hexagonal volumetric elements. The volume element nodes were connected to the shell by Distributed coupling – this was the most realistic option and has been used in this work.

The connection between the frame and the longitudinal beams was made using 3D elements – see Fig. 4.

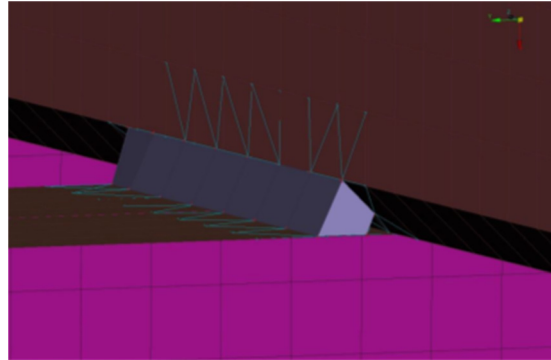

Fig. 4: Modeling of welded joints between frame and longitudinal profiles of container

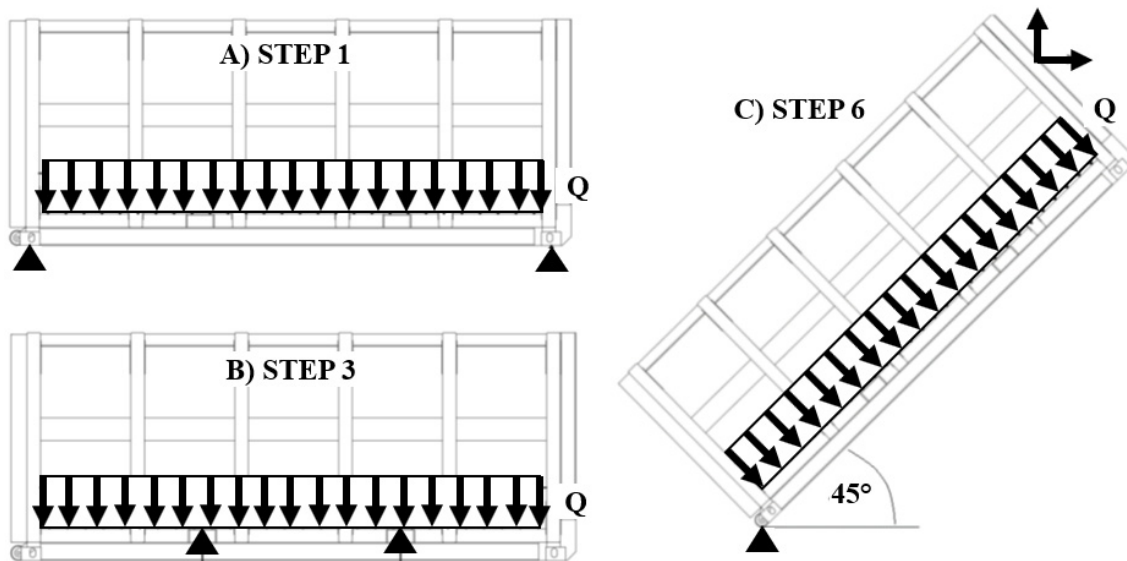

Fig. 5: Load scheme for selected steps – A) STEP 1; B) STEP 3; C) STEP 6

Six steps have been defined for calculations. All steps had same load force and different boundary conditions.

- STEP 1 – Container loaded (Q - total waste weight) in horizontal position and attached to four ISO corner elements (see Fig. 5 – A).
- STEP 2 – Container loaded (Q - total waste weight) in horizontal position and attached to rollers and handling eye.
- STEP 3 – Container loaded (Q - total waste weight) in horizontal position and attached to two holes for forklift (see Fig. 5 – B).
- STEP 4 and 5 – Container loaded (Q - total waste weight) in horizontal position and attached to three ISO corner elements – torsion simulation.

- STEP 6 – Container loaded (Q - total waste weight) in tilting the container at angle 45° and attached to rollers and handling eye (see Fig. 5 – C).

Results

The analytical and FEM stress-strain calculations were performed on the container. The stress should be less than 236 Nmm⁻² and in welds should be less than 100 Nmm⁻². Fig. 6 shown results for STEP 1 – view on whole construction and from bottom. Maximum stress was 228 Nmm⁻².

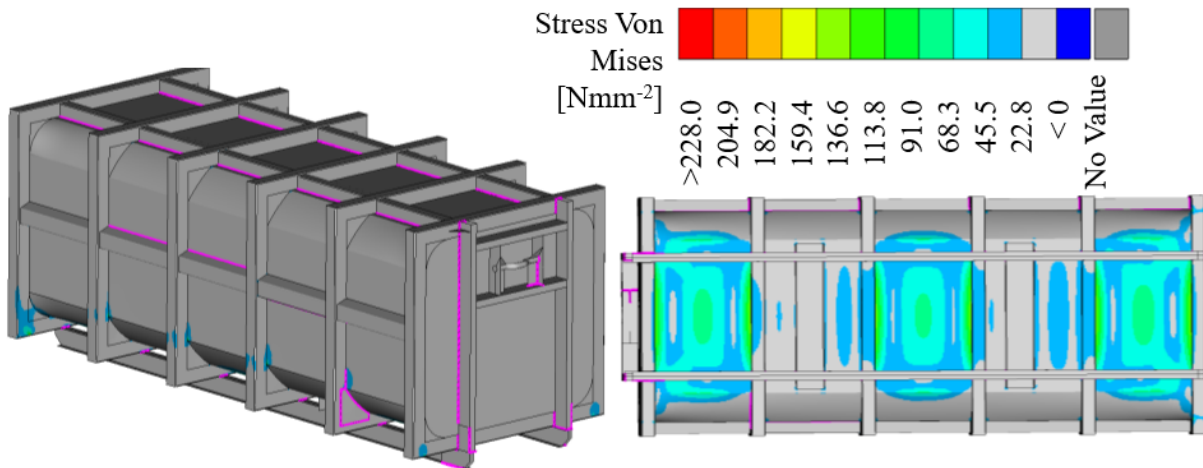

Fig. 6: Example of FEM simulation – Von Mises stress for STEP 1 (3D view and view from bottom)

Fig. 7 shown results for STEP 6 – view on whole construction and detail on handling eye. Maximum stress was 236 Nmm⁻².

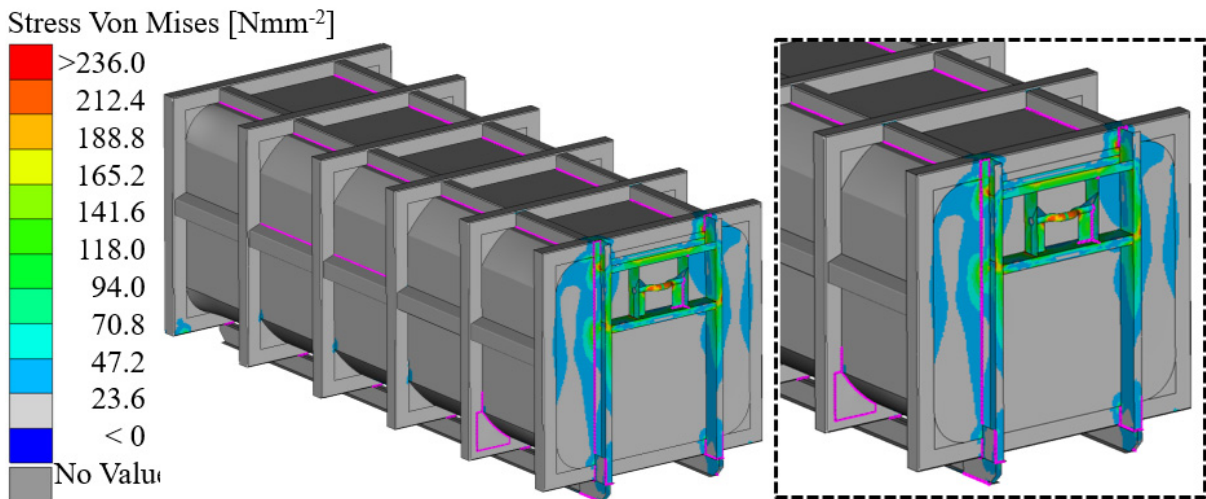

Fig. 7: Example of FEM simulation – Von Mises stress for STEP 6

After FEM calculation was been updated longitudinal beams (height of I-profile) and was been changed connection of hook into container. On the container was used I-profile for longitudinal beams and other profiles were created from bent profiles from sheet metals.

Conclusions

Thanks to the multi-step design, better container parameters have been achieved. The container was calculated in several steps with different stress and boundary conditions. Continuously carried out structural adjustments. This has resulted in a maximum volume and a minimum weight.

Acknowledgement

This work was funded by Operational Programme Prague – Growth Pole of the Czech Republic, project no. CZ.07.1.02/0.0/0.0/16-040/0000363.

References

- [1] Czech Technical University in Prague, Faculty of Mechanical Engineering, Technická 1902/4, 160 00 Prague 6, Czech Republic. A shipping container. Inventors: V. DYNBYL, et al. Czech Republic. Utility Model CZ 32039. 2018-06-22.
- [2] ISO 668:2013 Series 1 freight containers – Classification, dimensions and ratings.
- [3] HOBACHER, A. Recommendations for Fatigue Design of Welded Joints and Components. Springer International Publishing. 2016. ISBN 978-3-319-23756-5. DOI 10.1007/978-3-319-23757-2.